

# ENGINEERING DATA



Smith &  
Loveless, Inc.®

14040 Santa Fe Trail Drive  
Lenexa, Kansas 66215-1284

PISTA® 270™ Grit  
Removal System  
Specification  
April 2013  
Page J1

## SPECIFICATIONS FOR PISTA® 270™ GRIT REMOVAL SYSTEM

### GENERAL

The contractor shall furnish and install \_\_\_\_\_ Model \_\_\_\_ PISTA® 270™ Grit Chamber(s) in accordance with the drawings. Each PISTA® 270™ Grit Chamber shall be complete with the following equipment: gear motor, gear head, air bell, propeller drive tube, axial flow propeller, PISTA® 270™ Grit Removal Pump and auxiliary equipment as specified herein. All wetted parts shall be constructed of (epoxy coated carbon) (304 stainless) (316 stainless) steel.

The PISTA® 270™ Grit Removal Unit shall have less than 1/4" (6 mm) head loss and shall be capable of removing grit from raw waste or process water and depositing the grit in a storage hopper. No moving parts subject to wear or stoppage shall be below the water surface. An integral grit transporting means shall be provided to transport the grit from the storage hopper to the disposal means. To minimize the possibility of clogging, all internal openings in the piping to the grit pumping device as well as the grit pumping device shall be large enough to pass a 4" (100 mm) sphere. No bends or elbows will be allowed in the piping on the suction side of the Top-Mounted PISTA® TURBO™ Grit Pump. All drives, lubrication and bearings shall be readily accessible from walkways above the operating water level. To minimize the possibility of organic capture, the floor of the grit separation chamber shall be flat and there shall be no greater than a 3" (75 mm) opening for grit to pass through to the storage hopper. Sloping floors in the upper chamber will not be allowed due to reduced grit removal efficiency and extra construction costs. The PISTA® 270™ Grit Chamber shall be manufactured by Smith & Loveless®, Inc., Lenexa, Kansas.

An influent baffle or equivalent and inlet coanda ramp shall be provided to enhance the coanda effect and direct the grit downward to the bottom of the separation chamber as well as enhance chamber flow patterns.

### CONDITIONS OF OPERATION

The grit removal device shall be capable of removing the following at the specified hydraulic peak flow rate, and no decrease in efficiency will be allowed at flows less than this design rate.

- 95% of the grit greater than 50-mesh (300 microns) in size,
- 85% of the grit greater than 70-mesh (210 microns) but less than 50-mesh (300 microns) in size, and
- 65% of the grit greater than 100-mesh (150 microns) but less than 70-mesh (210 microns) in size.

The PISTA® 270™ Grit Chamber shall operate on the vortex principle. The described PISTA® 270™ Grit Chamber has been certified to meet the above performance in 2,500 previous installations of similar design and equipment. The above performance shall be proven in full scale field testing of over 50 installations utilizing certified grit removal efficiency test procedures as performed by qualified, Factory payroll personnel who have at least one (1) year experience performing the test.

To maximize grit removal efficiency, the grit chamber hydraulics shall incorporate a toroidal flow path enhanced by a slow vortex. Grit chambers incorporating the gravity principle will not be acceptable due to the turbulence in the flow, which prevents gravity settling from being effective and due to the extra area needed for settling fine grit. Aerated grit chambers, and those incorporating conventional settling criteria, are also specifically unacceptable.

To ensure the efficient transport of the grit and simultaneous lifting and discharge of the organic material, the bottom of the upper chamber covering the storage hopper shall be constructed of structural grade (epoxy coated carbon) (304 stainless) (316 stainless) steel plate, free from rotation, and shall be flat.

The grit moving across the bottom of the chamber shall be hydraulically scoured as the propeller blades, moving within 6" (150 mm) of the grit, pass over the moving grit and cause hydraulic currents to lift up the organics. The grit scouring intensity shall be adjustable. Propellers running with a center line greater than 8" (200 mm) from the bottom of the chamber will not be acceptable. The grit shall pass from the removal chamber through an opening in the transition plate and drop into a grit storage hopper.

# ENGINEERING DATA



Smith &  
Loveless, Inc.®

14040 Santa Fe Trail Drive  
Lenexa, Kansas 66215-1284

PISTA® 270™ Grit  
Removal System  
Specification  
April 2013  
Page J2

The flow in the removal chamber shall travel between the inlet and the outlet a minimum 270° (clockwise) (counterclockwise), providing maximum travel of the liquid for effective grit removal.

The PISTA® 270™ Grit Chamber shall handle all flows equal to or less than a hydraulic peak flow of ( \_\_\_\_\_ MGD) ( \_\_\_\_\_ CMD). The influent flume, transporting the liquid waste to the PISTA® 270™ Grit Chamber, shall be of the size and shape shown on the contract drawings to assure that grit does not settle in the inlet flume and to provide for proper operation of the PISTA® 270™ Grit Chamber. The effluent flume shall be a free-flowing flume for maintaining proper velocity within the chamber.

The PISTA® 270™ Grit Chamber shall be equipped with influent baffle in the inlet of the main chamber [*on Models 0.5 through 20.0 only*]. The influent baffle shall be designed to direct the inlet flow into the chamber in a manner ensuring the proper vortex flow and to prevent short-circuiting [*Models 30.0 through 100.0 do not require an inlet baffle*]. The baffle shall be constructed of (epoxy coated carbon) (304 stainless) (316 stainless) steel. The installing contractor shall attach the influent baffle to the concrete structure using 1/2" (13 mm) anchor bolts, as shown on the drawings. The discharge channel floor is to be at a constant elevation, as shown on the drawings.

## MECHANICAL DRIVE

The PISTA® Grit Removal Unit shall have an axial flow propeller connected by a drive tube through gearing to a 3-phase, \_\_\_\_\_ cycle, \_\_\_\_\_ volt, totally enclosed helical gear motor. The minimum rated horsepower (kilowatts) of the motor shall be ( \_\_\_\_\_ BHP) ( \_\_\_\_\_ kW).

The drive tube shall be driven by a large, totally enclosed combination spur gear and turntable bearing. The maximum output speed of the drive shall be 21 RPM. Pinions and gears shall be high quality steel, machined and hardened for high strength and long wear. Propeller blades shall be tapered, with generously rounded leading edge, to reduce energy consumption and prevent foreign material from fouling the propeller.

A pinion mounted on the output shaft of the helical gear motor shall drive a large spur tooth bull gear enclosed in a heavy cast-iron case. The spur gear pinion shall be cut from heat-treated steel. The bull gear shall rotate with a minimum 21" (533 mm) diameter turntable bearing for durability and stability. The pinion and bull gear shall have a service factor of 5.0 or greater at standard operating speeds.

All bearings of the drive unit, including the motor, shall have a minimum L-10 bearing life of 100,000 hours, except for the 21" (533 mm) diameter turntable bearing supporting the propeller assembly which shall have a minimum L-10 life of 20 years.

The bull gearbox shall be specifically designed for this service. It shall have an opening for the 10-3/4" (275 mm) diameter torque tube driving the propeller. The gearbox shall be sealed and the bottom opening shall have an air bell around the torque tube to prevent water from entering the gearbox in case of flooding. The top of the gearbox shall have a bolted flanged connection for the grit discharge pipe. Clarifier drives, which are modified to meet the higher propeller speed, specifically will not be acceptable. The drive motor shall have normal starting torque and low starting current. The motor shall not be overloaded beyond the nameplate rating under any normal conditions encountered.

## PISTA® GRIT FLUIDIZER

The PISTA® Grit Collection System shall be equipped with PISTA® Grit Fluidizer vanes. The PISTA® Grit Fluidizer vanes shall be located within six inches (6") (150 mm) of the elevation of the pump suction inlet. The PISTA® Grit Fluidizer vanes shall be bolted to the propeller drive tube in a helical fashion so as to gently pump the grit upward and keep the grit fluidized at the inlet of the PISTA® TURBO™ Grit Pump.

The PISTA® Grit Fluidizer vanes shall be fabricated of the same material as the drive tube and shall be bolted to the drive tube to facilitate easy removal.

The PISTA® Grit Fluidizer is a helical pump that provides two (2) functions.

# ENGINEERING DATA



Smith &  
Loveless, Inc.®

14040 Santa Fe Trail Drive  
Lenexa, Kansas 66215-1284

PISTA® 270™ Grit  
Removal System  
Specification  
April 2013  
Page J3

One, the PISTA® Grit Fluidizer vanes continuously pump the grit upward at the center of the PISTA® Grit Collection Chamber. This gentle pumping action prevents the grit from packing down around the pump suction pipe. If grit is left in the chamber too long, or has a sticky or greasy consistency, it can pack together, and the pull of water created by the pump might not break it loose. The PISTA® Grit Fluidizer vanes keep the grit fluidized at the suction inlet so packing cannot occur.

Second, the upward pumping action of the PISTA® Grit Fluidizer vanes enhance the performance of the propeller in keeping organics in suspension. The heavier grit can fall downward through the gently circulating water, but the organics are more readily swept away by the currents induced by the PISTA® propeller.

## GRIT STORAGE HOPPER

A grit storage hopper with a 60° sloped bottom shall be provided. The effective storage volume shall be \_\_\_ cubic feet (m<sup>3</sup>). To prevent squatly storage chambers the maximum diameter shall be ( \_\_\_'-\_\_\_" ) ( \_\_\_ m ). The minimum depth shall be ( \_\_\_'-\_\_\_" ) ( \_\_\_ m ). This is to allow for adequate volume for grit pile expansion if backwashing is performed plus allow adequate storage to prevent excessive numbers of grit removal cycles and grit handling equipment wear. As an integral part of the equipment installation, the Manufacturer shall supply a floor plate to cover the storage hopper. The plate shall consist of two (2) sections with lifting slots to allow access to the storage area. Attaching this plate as part of the rotating assembly will not be allowed.

## STEEL CHAMBER

### (OPTIONAL ITEM – CHECK IF REQUIRED)

The contractor shall provide, in addition to the grit chamber mechanism, a pre-fabricated 1/4" (6 mm) minimum thickness structural (carbon) (304 stainless) (316 stainless) steel chamber, baffles, bridges and integral channel transition pieces. The steel chamber assembly shall contain integral steel studs for attachment to the concrete channels, as shown on the drawings. (The concrete channels shall be formed after the chamber has been set in place.) Handrails shall be provided along both sides of the access bridge atop the chamber.

### PISTA® TURBO™ GRIT PUMP – TOP-MOUNTED

#### **[RECOMMENDED PUMPING OPTION #1 – CHECK IF SELECTED – TYPICALLY, MODELS 0.5 THRU 20.0 USE A 4" (100 MM) 250 GPM (15.8 LPS) PUMP AND MODELS 30.0 THRU 100.0 USE A 6" (150 MM) 500 GPM (31.6 LPS) PUMP]**

The PISTA® TURBO™ Grit Pump shall be a (4" or 100 mm) (6" or 150 mm) vertical, close-coupled, vacuum primed type with curved 5-vane flow inducer completely out of the flow path between the pump inlet and discharge connection, so that the grit pumped is not required to pass through the impeller. All internal clearances shall provide for the passage of a 4" (100 mm) spherical solid to preclude clogging of the pump and suction line. The pump shall be designed to be in-line mounted directly to a flange on top of the straight (4" or 100 mm) (6" or 150 mm) suction line. The suction line shall be vertical, passing up through the PISTA® Grit Chamber Drive to prevent accumulated grit from flowing into the suction pipe during idle periods and clogging the suction line. The pump shall be vertical, for easy removal of the motor and impeller, to facilitate maintenance of the suction line by providing a straight path to any potential blockage.

The pump shall be of Ni-Hard construction, with Ni-Hard impeller, and especially designed for the use of mechanical seals and vacuum priming. Self-priming type pumps are specifically not acceptable.

In order to minimize seal wear caused by lineal movement of the shaft, the shaft bearing nearest the pump impeller shall be locked in place so that end play is limited to the clearance within the bearing. To minimize seal wear resulting from shaft deflection caused by the radial thrust of the pump the shaft from the top of the impeller to the lower bearing supporting the impeller shall have a minimum diameter of 1-7/8" (48 mm) for a 4" (100 mm) pump or 2-1/8" (54 mm) for a 6" (150 mm) pump. The dimension from the lower bearing to the top of the impeller hub shall not exceed 6" (150 mm).

# ENGINEERING DATA



Smith &  
Loveless, Inc.®

14040 Santa Fe Trail Drive  
Lenexa, Kansas 66215-1284

PISTA® 270™ Grit  
Removal System  
Specification  
April 2013  
Page J4

The bottom bearing of the motor shall be locked in place and designed to handle all thrust loads and the necessary radial load. The upper bearing shall be free to move up and down and, thus, carry only radial load. This movement allows for thermal expansion of the shaft.

The shaft shall be solid stainless steel through the mechanical seal to eliminate corrosion and abrasive rust particles. Removable shaft sleeves will not be acceptable if the shaft under the sleeve does not meet the specified 1-7/8" (48 mm) minimum diameter for a 4" (100 mm) pump or 2-1/8" (54 mm) for a 6" (150 mm) pump. Carbon steel shafts are not acceptable.

The impeller shall produce a turbine-like flow pattern within the casing, generating flow. To prevent grit from entering the seal area, all impellers less than full diameter shall have an untrimmed back shroud so that a minimum clearance from shroud to casing is maintained. Both the end of the shaft and the bore of the impeller shall be tapered to permit easy removal of the impeller from the shaft.

The pump shall be specifically designed for vacuum priming service and have been in this service for a period of at least ten (10) years. The pump shall have an adapter providing a large water reservoir above the impeller to provide for positive exclusion of air from the impeller. The seal shall be inside this area to assure lubrication and grit shall be excluded from this area by a full size impeller shroud. Pumps, which do not use hollow priming adapters for positive lubrication of the seal, will not be acceptable.

The pump shall be arranged so that the complete rotating element can easily be removed from the casing without disconnecting the electrical wiring or disassembling the motor, impeller, backhead or seal.

The pump shall be sealed against leakage by a single mechanical seal, constructed so as to be automatically drained and automatically primed each time the pump is drained and primed. Water which lubricates the mechanical seal shall be automatically drained from around the seal if the pump loses prime in order to allow both the pump and the seal to be drained, thereby preventing freezing and breakage of the seal during power outages in sub-freezing temperatures.

The seal shall be of carbon and ceramic materials with the mating surface lapped to a flatness tolerance of one light band. The rotating ceramic shall be held in mating position with the stationary carbon by a stainless steel spring.

The **PISTA® TURBO™** Grit Pump shall be capable of delivering ( \_\_\_ GPM) ( \_\_\_ LPS) against a total dynamic head of ( \_\_\_') ( \_\_\_ m). The rated static suction lift (\_\_\_ specific gravity x ( \_\_\_') ( \_\_\_ m) elevation difference) shall be ( \_\_\_') ( \_\_\_ m) of water at an elevation of \_\_\_' ( \_\_\_ m) above mean sea level. The maximum allowable speed shall be \_\_\_ RPM. The minimum rated horsepower (kilowatts) of the **PISTA® TURBO™** Grit Pump motor shall be ( \_\_\_BHP) ( \_\_\_ kW).

The pump motor shall be vertical, solid shaft, TEFC NEMA P-base, squirrel-cage induction-type, suitable for 3-phase, \_\_\_ cycle, \_\_\_ volt electric current. It shall have Class F insulation, but the motor shall have Class B temperature limits. The motor shall have normal starting torque and low starting current, as specified for NEMA Design B characteristics. It shall have a 1.15 service factor.

The motor-pump shaft shall be centered, in relation to the motor base, within .005" (0.13 mm). The shaft run-out shall be limited to .003" (0.08 mm).

A bearing cap shall be provided to hold the bottom motor bearing in a fixed position. Bearing housings shall be provided with fittings for lubrication as well as purging old lubricant.

The motor shall be fitted with heavy lifting eyes or lugs, each capable of supporting the entire weight of the pump and motor.

# ENGINEERING DATA



Smith &  
Loveless, Inc.®

14040 Santa Fe Trail Drive  
Lenexa, Kansas 66215-1284

PISTA® 270™ Grit  
Removal System  
Specification  
April 2013  
Page J5

## □ PISTA® TURBO™ GRIT PUMP – REMOTE MOUNTED [ALTERNATE PUMPING OPTION #2 – CHECK IF SELECTED– TYPICALLY, MODELS 0.5 THRU 20.0 USE A 4” (100 MM) 250 GPM (15.8 LPS) PUMP AND MODELS 30.0 THRU 100.0 USE A 6” (150 MM) 500 GPM (31.6 LPS) PUMP]

The PISTA® TURBO™ Grit Pump shall be a (4” or 100 mm) (6” or 150 mm) vertical, close-coupled type with curved 5-vane flow inducer completely out of the flow path between the pump inlet and discharge connection, so that the grit pumped is not required to pass through the impeller. All internal clearances shall provide for the passage of a 4” (100 mm) spherical solid to preclude clogging of the pump and suction line. The pump shall be vertical, for easy removal of the motor and impeller, to facilitate maintenance of the suction line by providing a straight path to any potential blockage.

The pump shall be of Ni-Hard construction, with Ni-Hard impeller, and especially designed for the use of mechanical seals.

In order to minimize seal wear caused by lineal movement of the shaft, the shaft bearing nearest the pump impeller shall be locked in place so that end play is limited to the clearance within the bearing. To minimize seal wear resulting from shaft deflection caused by the radial thrust of the pump the shaft from the top of the impeller to the lower bearing supporting the impeller shall have a minimum diameter of 1-7/8” (48 mm) for a 4” (100 mm) pump or 2-1/8” (54 mm) for a 6” (150 mm) pump. The dimension from the lower bearing to the top of the impeller hub shall not exceed 6” (150 mm).

The bottom bearing of the motor shall be locked in place and designed to handle all thrust loads and the necessary radial load. The upper bearing shall be free to move up and down and, thus, carry only radial load. This movement allows for thermal expansion of the shaft.

The shaft shall be solid stainless steel through the mechanical seal to eliminate corrosion and abrasive rust particles. Removable shaft sleeves will not be acceptable if the shaft under the sleeve does not meet the specified 1-7/8” (48 mm) minimum diameter for a 4” (100 mm) pump or 2-1/8” (54 mm) for a 6” (150 mm) pump. Carbon steel shafts are not acceptable.

The impeller shall produce a turbine-like flow pattern within the casing, generating flow. To prevent grit from entering the seal area, all impellers less than full diameter shall be trimmed with the back shroud remaining full diameter so that a minimum clearance from shroud to casing is maintained. Both the end of the shaft and the bore of the impeller shall be tapered to permit easy removal of the impeller from the shaft.

The pump shall be arranged so that the complete rotating element can easily be removed from the casing without disconnecting the electrical wiring or disassembling the motor, impeller, backhead or seal.

The pump shall be supported by a heavy base with four (4) legs to provide maximum rigidity and balance. Anchor bolts are not included. For ease of maintenance, an isolation plug valve should be installed on each side of the pump.

The PISTA® TURBO™ Grit Pump shall be capable of delivering ( \_\_\_ GPM) ( \_\_\_ LPS) against a total dynamic head of ( \_\_\_' ) ( \_\_\_ m). The maximum allowable speed shall be \_\_\_ RPM. The minimum rated horsepower (kilowatts) of the PISTA® TURBO™ Grit Pump motor shall be ( \_\_\_ BHP) ( \_\_\_ kW).

The pump motor shall be vertical, solid shaft, TEFC NEMA P-base, squirrel-cage induction-type, suitable for 3-phase, \_\_\_ cycle, \_\_\_ volt electric current. It shall have Class F insulation, but the motor shall have Class B temperature limits. The motor shall have normal starting torque and low starting current, as specified for NEMA Design B characteristics. It shall have a 1.15 service factor.

The motor-pump shaft shall be centered, in relation to the motor base, within .005” (0.13 mm). The shaft run-out shall be limited to .003” (0.08 mm).

A bearing cap shall be provided to hold the bottom motor bearing in a fixed position. Bearing housings shall be provided with fittings for lubrication as well as purging old lubricant.



# ENGINEERING DATA



Smith &  
Loveless, Inc.®

14040 Santa Fe Trail Drive  
Lenexa, Kansas 66215-1284

PISTA® 270™ Grit  
Removal System  
Specification  
April 2013  
Page J6

The motor shall be fitted with heavy lifting eyes or lugs, each capable of supporting the entire weight of the pump and motor.

## MINIMUM PUMP REQUIREMENTS

Shaft through seal:	1-7/8" (48 mm) Diameter, Solid Stainless Steel (4" or 100 mm Pump); 2-1/8" (54 mm) Diameter, Solid Stainless Steel (6" or 150 mm Pump)
Lower bearing to impeller distance:	6" (150 mm) Maximum
Shaft run-out:	0.003" (0.08 mm) Maximum
Shaft end play:	Limited to bearing shake
Shaft to motor base:	0.005" (0.13 mm) Maximum
Impeller to shaft fit:	Tapered
Impeller:	
Type:	Recessed 5-Vane PISTA® TURBO™
Material:	Ni-Hard - High nickel iron
Shroud:	Untrimmed - Full diameter
Seal housing:	Bronze
Fronthead to casing:	One piece
Backhead & motor adapter:	One piece
Upper bearing:	Axially free
Lower bearing:	Locked in place
Motor insulation:	Class F
Motor temperature rise:	Class B
Motor service factor:	1.15

Pumps will only be considered if all of the above requirements are met as a minimum. These requirements are specified for long service life and ease of operator maintenance. Deviations from the PISTA® TURBO™ Grit Pump specifications will be cause for rejection.

## ☐ VACUUM PRIMING SYSTEM (CHECK IF USING THE TOP MOUNTED PISTA® TURBO™ GRIT PUMP)

The vacuum priming panel shall be located adjacent to the PISTA® TURBO™ Grit Pump in a weatherproof enclosure mounted on the drive unit for the PISTA® Grit Chamber. The system shall be complete with vacuum pump, vacuum control solenoid valve and resonant frequency prime level sensor located on the pump, heater, and a float-operated check valve installed in the system ahead of the vacuum pump to prevent liquid from entering the vacuum pump. The float-operated check valve shall have a transparent body for visual inspection of the liquid level and shall be automatically drained when the vacuum pump shuts off. All hoses and tubing used in the priming system shall be at least 3/8" (9.5 mm) nominal diameter.

The vacuum control solenoid valve shall be mounted directly on the PISTA® TURBO™ Grit Pump priming dome, to keep pump discharge pressure from the vacuum tubing and fittings and minimize the residual air pocket after priming.

The vacuum pump shall have corrosion resistant internal components. It shall be capable of priming the PISTA® TURBO™ Grit Pump and grit removal piping in not greater than 60 seconds under rated static lift conditions.

Liquid level in the pump priming chamber shall be monitored by a SONIC START® resonant frequency liquid level probe. The SONIC START® probe shall be equipped with a piezoelectric drive and sensitive circuits to detect frequency shifts when the probe is covered by liquid. The SONIC START® probe shall be completely sealed and have a 316L stainless steel housing for corrosion resistance. It shall be provided with a wiring connector molded of PolyPhenylSulfone, an amorphous high performance thermoplastic for impact and chemical resistance. The SONIC START® probe shall have a plug-in connector to facilitate easy removal.

# ENGINEERING DATA



Smith &  
Loveless, Inc.®

14040 Santa Fe Trail Drive  
Lenexa, Kansas 66215-1284

PISTA® 270™ Grit  
Removal System  
Specification  
April 2013  
Page J7

The SONIC START® probe shall be provided with light emitting diodes. This diagnostic tool shall indicate connectivity, prime status or a fault condition. Systems utilizing an electrode, mechanical means such as a float, or that require any type of electrical or moving parts inside the priming chamber, which may accumulate debris, short out, bind or fail will not be acceptable.

The priming system shall automatically provide positive lubrication of the mechanical seal each time the PISTA® TURBO™ Grit Pump is primed. To prevent excessive stoppage due to grit accumulation, no passageway in the priming system through which grit must pass shall be smaller than the equivalent of a 2-1/2" (64 mm) opening. Priming from high-pressure (gauge) connections will not be acceptable.

## COLD WEATHER PACKAGE (OPTIONAL ITEM – CHECK IF REQUIRED)

The Vacuum Priming System Panel shall be provided with a rigidly mounted, thermostatically controlled 400-watt heater.

## EXTREME COLD WEATHER PACKAGE (OPTIONAL ITEM – CHECK IF REQUIRED - SEE MAP IN "PISTA® NOTES ON DESIGN" FOR AREAS WHERE THIS OPTION IS RECOMMENDED FOR OUTDOOR INSTALLATIONS)

The Vacuum Priming System panel shall be provided with a rigidly mounted, thermostatically controlled 800-watt heater. In addition, an insulated, heat traced jacket shall be provided to protect the priming dome and solenoid valve from freezing temperatures. The jacket shall be flexible, weatherproof and easily removable for servicing the dome or solenoid valve, if required, by separating the hook and loop fasteners which secure it in place. The jacket shall have a 30 watt heat trace cable, of corrosion resistant construction, which is self regulating. The 120v heater shall be wired to a circuit breaker in the control panel, through the pump motor conduit box and shall have a quick disconnect connector near the priming dome to facilitate removal or replacement.

## LIFTING STANCHION

### (OPTIONAL ITEM – CHECK IF REQUIRED)

A stanchion with lifting arm shall be provided to lift the PISTA® TURBO™ Grit Pump for disassembly. The lifting arm shall have a hook over the center of the motor to support a hoist provided by the Owner. Installation shall be as detailed in the contract drawings. The lifter shall be designed for a 1,000 lb. (454 kg) lifting load.

## ELECTRICAL CONTROLS FOR AUTOMATIC GRIT REMOVAL [CONTROL OPTION #1 – CHECK IF SELECTED]

The electrical control equipment shall be mounted in a NEMA Type 4 steel enclosure with removable access cover. Thermal magnetic air circuit breakers shall be provided for branch disconnect service and short-circuit protection of all motor control and auxiliary circuits.

Magnetic across-the-line starters with overload coils for each phase shall be provided for the PISTA® TURBO™ Grit Pump Motor, [PISTA® Grit Screw Conveyor] and drive motor for the propeller drive unit. Each single-phase auxiliary motor shall be equipped with an over-current protection device, in addition to the branch circuit breaker, or shall be impedance protected. All switches shall be labeled and a coded wiring diagram shall be provided.

An On-Off selector switch shall be provided to operate the propeller drive motor starter.

To control the operation of the PISTA® TURBO™ Grit Pump, a manual Momentary-Off-Automatic selector switch shall be provided. In the automatic position, control shall be by a time clock with manual selector switch to override the timer and initiate the pumping [and PISTA® Grit Screw Conveyor] cycle. A 24-hour, 96-position time clock shall be provided. The 24-hour timer contacts shall operate a 0-30-Minute Pump Timer (and a 0-30-Minute priming timer)[and an adjustable off-delay timer for the PISTA® Grit Screw Conveyor]. All timers shall be provided within the control cabinet enclosure.

# ENGINEERING DATA



Smith &  
Loveless, Inc.®

14040 Santa Fe Trail Drive  
Lenexa, Kansas 66215-1284

PISTA® 270™ Grit  
Removal System  
Specification  
April 2013  
Page J8

## PNEUMATICALLY CONTROLLED DISCHARGE PINCH VALVE (CHECK IF USING THE TOP-MOUNTED PISTA® TURBO™ GRIT PUMP)

A pneumatically controlled discharge pinch valve shall be furnished for installation in the vertical discharge piping run, and the controls shall be located in the vacuum priming control panel. The controls shall include an oil-less air compressor and solenoid valve. The operation of the discharge pinch valve shall be tied into the cycle timer and the SONIC START® level sensor, so as to be fully automatic.

## PRIME FAILURE ALARM (CHECK IF USING THE TOP-MOUNTED PISTA® TURBO™ GRIT PUMP)

A “prime failure” alarm shall be initiated if pump does not prime before time set on the priming timer. Interlocks shall be provided to prevent the PISTA® TURBO™ Grit Pump from operating if the pump is not primed.

All necessary capacitors, relays, diodes, etc., shall be provided as shown on the schematic diagram. In order to ensure continuity of operation, the Manufacturer of the PISTA® Grit Chamber shall provide these controls, and the full-opening pneumatically controlled pinch valve for installation on the grit discharge line as shown on the drawings.

## ELECTRICAL CONTROLS FOR MANUALLY ACTIVATED GRIT REMOVAL [CONTROL OPTION #2 – CHECK IF REQUIRED]

The electrical control equipment shall be mounted in a NEMA Type 4 steel enclosure with hinged access cover. Thermal magnetic air circuit breakers shall be provided for branch disconnect service and short circuit protection of all motor control and auxiliary circuits.

Magnetic across-the-line starters with under-voltage release and overload coils for each phase shall be provided for the PISTA® TURBO™ Grit Pump Motor, [PISTA® Grit Screw Conveyor] and drive motor for the propeller drive unit. Each single-phase auxiliary motor shall be equipped with an over-current protection device, in addition to the branch circuit breaker, or shall be impedance protected. All switches shall be labeled and a coded wiring diagram shall be provided.

On-Off selector switches shall be provided to control the operation of the PISTA® TURBO™ Grit Pump, [PISTA® Grit Screw Conveyor] and propeller drive motor starters. Interlocks shall be provided to prevent the PISTA® TURBO™ Grit Pump from operating if the pump is not primed. All necessary resistors, relays, diodes, etc., shall be provided as shown on the schematic diagram.

A ( \_\_\_\_\_ ” ) ( \_\_\_\_\_ m) eccentric plug valve with lever operator and resilient seat shall be provided for installation in the pump discharge line to isolate the pump for priming.

## CONTROL TRANSFORMER

### (OPTIONAL ITEM – CHECK IF SELECTED)

A properly sized insulating-type control transformer shall be provided by the controls Manufacturer to supply power for controls and auxiliary devices necessary to semi-automatic operation. The control transformer shall have \_\_\_\_\_ Volt AC primary, 120-volt AC secondary, Class F insulation; with temperature rise not to exceed 115°C above a 40°C ambient.

### PISTA® GRIT CONCENTRATOR – 250 GPM (15.8 LPS) [CHECK IF SELECTED – TYPICALLY MODELS 0.5 THRU 20.0 USE A 250 GPM (15.8 LPS) CONCENTRATOR]

The second stage PISTA® Grit Concentrator shall be provided as shown on the drawings for secondary treatment of organics and secondary grit dewatering. The PISTA® Grit Concentrator shall operate on the constant rate vortex principle. Design shall be such that a small volume of water and the grit will discharge at the bottom for final dewatering and ultimate disposal of the grit.



# ENGINEERING DATA



Smith &  
Loveless, Inc.®

14040 Santa Fe Trail Drive  
Lenexa, Kansas 66215-1284

PISTA® 270™ Grit  
Removal System  
Specification  
April 2013  
Page J9

As a minimum, 93 to 94 percent of the water pumped to the PISTA® Grit Concentrator and 95 to 96 percent of the residual organic material shall flow out the top and be returned to the inlet channel to the PISTA® Grit Chamber. The unit shall be capable of intermittent operation with minimal variation in removal efficiency. There shall be less than 5% putrescible material in the recovered grit from the underflow.

The PISTA® Grit Concentrator shall be constructed of Ni-Hard, with a minimum thickness of 1-1/4" (32 mm) in high wear areas. Inlet and outlet connections shall be as shown on the drawings. The PISTA® Grit Concentrator shall be provided by the Manufacturer of the PISTA® Grit Chamber, for installation by the contractor. The operating range shall be compatible with the total PISTA® Grit Removal System as described herein.

**PISTA® DURALYTE® GRIT CONCENTRATOR – 500 GPM (31.6 LPS)  
[CHECK IF SELECTED – TYPICALLY MODELS 30.0 THRU 100.0 USE A 500 GPM  
(31.6 LPS) CONCENTRATOR]**

The second stage PISTA® DURALYTE® Grit Concentrator shall be provided as shown on the drawings for secondary treatment of organics and secondary grit dewatering. The PISTA® DURALYTE® Grit Concentrator shall operate on the constant rate vortex principle. Design shall be such that a small volume of water and grit will discharge at the bottom for final dewatering and ultimate disposal of the grit.

As a minimum, 93 to 94 percent of the water pumped to the PISTA® DURALYTE® Grit Concentrator and 95 to 96 percent of the residual organic material shall flow out the top and be returned to the inlet channel of the PISTA® Grit Chamber. The unit shall be capable of intermittent operation with minimal variation in removal efficiency. There shall be less than 5% putrescible material in the recovered grit from the underflow.

The 2-piece PISTA® DURALYTE® Grit Concentrator shall be constructed of a Ni-Hard top section, with a minimum thickness of 3/4" (13 mm) in high wear areas, and a bottom cone constructed of a proprietary blend of 3/4" (20 mm) thick polyurethane. Additionally, a proprietary blend of silicon carbide with a minimum thickness of 1/2" (13 mm) shall be molded within the high wear area of the bottom portion of the polyurethane cone. Inlet and outlet connections shall be as shown on the drawings. The PISTA® DURALYTE® Grit Concentrator shall be provided by the Manufacturer of the PISTA® Grit Chamber, for installation by the contractor. The operating range shall be compatible with the total PISTA® Grit Removal System as described herein.

**MODEL 250 PISTA® TURBO™ GRIT WASHER WITH PARALLEL PLATE SEPARATOR  
(INCLUDING A 250 GPM (15.8 LPS) CONCENTRATOR) (SEE PISTA® TURBO™ GRIT  
WASHER ATTACHMENT FOR ADDITIONAL PISTA® TURBO™ GRIT WASHER  
DETAILS)  
[DEWATERING OPTION #1 – CHECK IF SELECTED]**

The PISTA® TURBO™ Grit Washer shall have 3 wash levels: High air scour, intense flushing with water and thorough agitation. The high air scour and intense flushing with water shall occur in the inlet hopper of the PISTA® TURBO™ Grit Washer. The flights on the screw shall be specially designed to further clean the grit through additional agitation, dewater the grit and dispose of the cleaned, dewatered grit.

The PISTA® TURBO™ Grit Washer device shall be capable of the following conditions of operation when operated at the specified rate of grit input and hydraulic peak flow rate, and preceded by a 1/4" (6 mm) or less screen:

**ORGANIC REMOVAL:** Less than or equal to 5% putrescible material remaining in the washed grit

**WATER CONTENT:** Less than or equal to 10% in the washed grit and capable of passing a "Paint Filter" test

**RETENTION OF GRIT:** 95% of Grit > 140 mesh (105 microns) in particle size, removed by the PISTA® TURBO™ Grit Washer

# ENGINEERING DATA



Smith &  
Loveless, Inc.®

14040 Santa Fe Trail Drive  
Lenexa, Kansas 66215-1284

PISTA® 270™ Grit  
Removal System  
Specification  
April 2013  
Page J10

## MAXIMUM GRIT SLURRY FEED RATE:

Model 250: 250 – 275 GPM (15.8 - 17.4 LPS)

## CAPACITY:

Model 250 – (41 ft<sup>3</sup>/hr or 1.2 m<sup>3</sup>/hr) (2.47 tons/hr or 2.2 tonnes/hr)

## PIPING CONNECTIONS:

Model 250: 4" (100 mm) inlet to PISTA® Grit Concentrator – plain end  
4" (100 mm) overflow – flanged hopper  
6" (150 mm) overflow – flanged PISTA® Grit Concentrator  
3" (75 mm) organic drain – threaded  
2" NPT drain (2 typ.)  
1" NPT water connection  
1/4" NPT air connection

**FLUSH WATER REQUIREMENTS:** 20 GPM @ 60 psi (109 cmd @ 4.1 bar). Intermittent. To aid in organics separation. **[NOTE TO DESIGNER: WATER SUPPLY MAY BE NON-POTABLE, HOWEVER NOT WASTEWATER. IF A POTABLE SUPPLY IS USED, A BACKFLOW PREVENTER SHOULD BE PROVIDED.]**

**AIR REQUIREMENTS:** 5 SCFH @ 70 psi ( 0.1 m<sup>3</sup>/hr @ 4.8 bar). Intermittent. To aid in organics separation. **[DESIGNER SELECT ONE OF THE FOLLOWING]**

### [OPTION #1 – CHECK IF SELECTED]

The air required shall be provided by piping in from the main plant air supply, as shown on the drawings.

### [OPTION #2 – CHECK IF SELECTED]

The air requirement shall be provided by an air compressor package, consisting of a 1/3 hp (0.2 kW) 1/60/115v oil-less motor-compressor unit with intake filter/silencer and a 2-gallon (7.6 liter) air storage tank with pressure switch, regulator and associated piping. The compressor shall have permanently lubricated bearings, stainless steel valves and lightweight aluminum construction. The air storage tank shall have a pressure gauge and safety relief valve.

The PISTA® TURBO™ Grit Washer shall be constructed of (304 stainless) (316 stainless) (epoxy coated carbon) **[DESIGNER: SELECT AS REQUIRED]** steel, including the screw. The inlet hopper receives the mixture of water and grit, and shall be equipped with an energy dissipation zone to prevent turbulence in the remaining portion of the hopper. The hopper shall have parallel plates located in the settling zone to improve retention of the fine grit. An overflow weir trough shall be provided to return the water to the system. The conveyor shall be freestanding with support legs to hold the conveyor at an angle of approximately 22°. The discharge shall be 8" (200 mm) diameter, plain-end pipe. The drive assembly shall be located at the discharge end.

The PISTA® TURBO™ Grit Washer shall have an open, 3/16" (5 mm) thick steel U-trough. The screw shall be 9" (230 mm) in diameter with mixer fluidizing vanes in the inlet hopper and shall have a continuous shaft design off the flight segment. The conveyor shall be 15' (4.6 m) in length, with overall dimensions as shown on the drawing. The hopper shall have a full-width outlet weir trough to minimize the carryover of the fine grit. The projected separator plate settling area shall be a minimum of 17.0 square feet (1.6 square meters).

The screw shall run on anti-friction bearings at the outlet end, and a bronze bushing at the inlet end. The inlet end shaft bushing shall be capable of being greased. The inlet end shall have two 2" (50 mm) drains. Clearance between the legs and the discharge outlet shall be as shown on the drawing.

# ENGINEERING DATA



Smith &  
Loveless, Inc.®

14040 Santa Fe Trail Drive  
Lenexa, Kansas 66215-1284

PISTA® 270™ Grit  
Removal System  
Specification  
April 2013  
Page J11

The drive to the PISTA® TURBO™ Grit Washer shall be a belt-driven, shaft-mounted helical gear reducer. The motor shall be 3 HP (2.2 kW), \_\_\_\_\_ rpm, (TEFC) (Class 1, Division 1 rated) **[DESIGNER: SELECT AS REQUIRED]** 3-phase, \_\_\_\_\_ cycle, \_\_\_\_\_ volt with a 1.0 Service Factor. The screw speed shall be 10RPM. The drive shall be mounted on a plate at the discharge end and the plate shall be bolted to the flanges on the trough.

Belt guards and covers shall be provided and manufactured in accordance with ASME B15.1-1992 Safety Standard For Mechanical Power Transmission Apparatus. Each belt guard shall have a metal label riveted to the exterior face, reading

“DANGER – LOCK OUT BEFORE SERVICING” and another metal label riveted to the interior face, reading: “WARNING – DO NOT OPERATE MACHINE WITHOUT GUARDS IN PLACE”.

A 1/8” (3 mm) thick expanded metal-flattened mesh cover, matching the construction of the PISTA® TURBO™ Grit Washer, shall be provided over the hopper and trough openings, as shown on the drawings.

## **[DESIGNER: DELETE THE FOLLOWING PARAGRAPH IF CARBON STEEL CONSTRUCTION IS SELECTED]**

[All structural stainless steel shall be thoroughly cleaned and then blasted for a uniform finish. The blasted surfaces shall then be protected by the application of a low viscosity oil with penetrating, lubricating and corrosion resistance properties.]

All carbon steel surfaces shall be cleaned and coated with 6-8 mils (0.15 – 2 mm) dry film thickness of VERSAPOX® epoxy coating, Factory-applied prior to shipment.

## **MODEL 500 PISTA® TURBO™ GRIT WASHER WITH PARALLEL PLATE SEPARATOR (INCLUDING A 500 GPM (31.6 LPS) CONCENTRATOR) (SEE PISTA® TURBO™ GRIT WASHER ATTACHMENT FOR ADDITIONAL PISTA® TURBO™ GRIT WASHER DETAILS)**

### **[DEWATERING OPTION #2 – CHECK IF SELECTED]**

The PISTA® TURBO™ Grit Washer shall have 3 wash levels: High air scour, intense flushing with water and thorough agitation. The high air scour and intense flushing with water shall occur in the inlet hopper of the PISTA® TURBO™ Grit Washer. The flights on the screw shall be specially designed to further clean the grit through additional agitation, dewater the grit and dispose of the cleaned, dewatered grit.

The PISTA® TURBO™ Grit Washer device shall be capable of the following conditions of operation when operated at the specified rate of grit input and hydraulic peak flow rate, and preceded by a 1/4” (6 mm) or less screen:

**ORGANIC REMOVAL:** Less than or equal to 5% putrescible material remaining in the washed grit

**WATER CONTENT:** Less than or equal to 10% in the washed grit and capable of passing a “Paint Filter” test

**RETENTION OF GRIT:** 95% of Grit > 140 mesh (105 microns) in particle size, removed by the PISTA® TURBO™ Grit Washer

### **MAXIMUM GRIT SLURRY FEED RATE:**

Model 500: 500 – 550 GPM (31.6 - 34.7 LPS)

### **CAPACITY:**

Model 500 – (172 ft<sup>3</sup>/hr or 4.9 m<sup>3</sup>/hr) (10.36 tons/hr)

# ENGINEERING DATA



Smith &  
Loveless, Inc.®

14040 Santa Fe Trail Drive  
Lenexa, Kansas 66215-1284

PISTA® 270™ Grit  
Removal System  
Specification  
April 2013  
Page J12

## PIPING CONNECTIONS:

Model 500: 4" (100 mm) inlet to PISTA® Grit Concentrator – plain end  
6" (150 mm) overflow – flanged hopper  
6" (150 mm) overflow – flanged PISTA® Grit Concentrator  
3" (75 mm) organic drain - threaded  
2" NPT drain (2 typ.)  
1-1/2" NPT water connection  
1/4" NPT air connection

**FLUSH WATER REQUIREMENTS:** 20 GPM @ 60 psi (109 cmd @ 4.1 bar). Intermittent. To aid in organics separation. **[NOTE TO DESIGNER: WATER SUPPLY MAY BE NON-POTABLE, HOWEVER NOT WASTEWATER. IF A POTABLE SUPPLY IS USED, A BACKFLOW PREVENTER SHOULD BE PROVIDED.]**

**AIR REQUIREMENTS:** 5 SCFH @ 70 psi ( 0.1 m<sup>3</sup>/hr @ 4.8 bar). Intermittent. To aid in organics separation. **[DESIGNER SELECT ONE OF THE FOLLOWING]**

### [OPTION #1 – CHECK IF SELECTED]

The air required shall be provided by piping in from the main plant air supply, as shown on the drawings.

### [OPTION #2 – CHECK IF SELECTED]

The air requirement shall be provided by an air compressor package, consisting of a 1/3 hp (0.2 kW) 1/60/115v oil-less motor-compressor unit with intake filter/silencer and a 2-gallon (7.6 liter) air storage tank with pressure switch, regulator and associated piping. The compressor shall have permanently lubricated bearings, stainless steel valves and lightweight aluminum construction. The air storage tank shall have a pressure gauge and safety relief valve.

The PISTA® TURBO™ Grit Washer shall be constructed of (304 stainless) (316 stainless) (epoxy coated carbon) **[DESIGNER: SELECT AS REQUIRED]** steel, including the screw. The inlet hopper receives the mixture of water and grit, and shall be equipped with an energy dissipation zone to prevent turbulence in the remaining portion of the hopper. The hopper shall have parallel plates located in the settling zone to improve retention of the fine grit. An overflow weir trough shall be provided to return the water to the system. The conveyor shall be freestanding with support legs to hold the conveyor at an angle of approximately 22°. The discharge shall be 12" (300 mm) diameter, plain-end pipe. The drive assembly shall be located at the discharge end.

The PISTA® TURBO™ Grit Washer shall have an open, 3/16" (5 mm) thick steel U-trough. The screw shall be 14" (355 mm) in diameter with mixer fluidizing vanes in the inlet hopper and shall have a continuous shaft design off the flight segment. The conveyor shall be 17' (5.2 m) in length, with overall dimensions as shown on the drawing. The hopper shall have a full-width

outlet weir trough to minimize the carryover of the fine grit. The projected separator plate settling area shall be a minimum of 35.5 square feet (3.3 square meters).

The screw shall run on anti-friction bearings at the outlet end, and a bronze bushing at the inlet end. The inlet end shaft bushing shall be capable of being greased. The inlet end shall have two 2" (50 mm) drains. Clearance between the legs and the discharge outlet shall be as shown on the drawing.

The drive to the PISTA® TURBO™ Grit Washer shall be a belt-driven, shaft-mounted helical gear reducer. The motor shall be 5 HP (3.7 kW), \_\_\_\_ rpm, (TEFC) (Class 1, Division 1 rated) **[DESIGNER: SELECT AS REQUIRED]** 3-phase, \_\_\_\_ cycle, \_\_\_\_ volt with a 1.0 Service Factor. The screw speed shall be 11 RPM. The drive shall be mounted on a plate at the discharge end and the plate shall be bolted to the flanges on the trough.

# ENGINEERING DATA



Smith &  
Loveless, Inc.®

14040 Santa Fe Trail Drive  
Lenexa, Kansas 66215-1284

PISTA® 270™ Grit  
Removal System  
Specification  
April 2013  
Page J13

Belt guards and covers shall be provided and manufactured in accordance with ASME B15.1-1992 Safety Standard For Mechanical Power Transmission Apparatus. Each belt guard shall have a metal label riveted to the exterior face, reading “DANGER - LOCK OUT BEFORE SERVICING”, and another metal label riveted to the interior face, reading “WARNING – DO NOT OPERATE MACHINE WITHOUT GUARDS IN PLACE”.

A 1/8” (3 mm) thick expanded metal-flattened mesh cover, matching the construction of the PISTA® TURBO™ Grit Washer, shall be provided over the hopper and trough openings, as shown on the drawings.

## **[DESIGNER: DELETE THE FOLLOWING PARAGRAPH IF CARBON STEEL CONSTRUCTION IS SELECTED]**

[All structural stainless steel shall be thoroughly cleaned and then blasted for a uniform finish. The blasted surfaces shall then be protected by the application of a low viscosity oil with penetrating, lubricating and corrosion resistance properties.]

All carbon steel surfaces shall be cleaned and coated with 6-8 mils (0.15 – 0.20 mm) dry film thickness of VERSAPOX® epoxy coating, Factory-applied prior to shipment.

### **☐ MODEL 15 PISTA® GRIT SCREW CONVEYOR WITH PARALLEL PLATE SEPARATOR (FOR USE WITH A 250 GPM (15.8 LPS) CONCENTRATOR) [DEWATERING OPTION #3 – CHECK IF SELECTED]**

The PISTA® Grit Screw Conveyor shall be constructed of (epoxy coated carbon) (304 stainless) (316 stainless) steel with an inlet hopper to receive the mixture of water and grit. The hopper shall be equipped with an energy dissipation zone to prevent turbulence in the remaining portion of the hopper. The hopper shall have parallel plates located in the settling zone to improve retention of the fine grit. An overflow weir trough shall be provided to return the water to the system. The conveyor shall be freestanding with support legs to hold the conveyor at an angle of approximately 22°. The discharge shall be 8” (200 mm) diameter, plain-end pipe. The drive assembly shall be located at the discharge end.

The PISTA® Grit Screw Conveyor shall have an open, 3/16” (5 mm) steel U-trough. The screw shall be 9” (230 mm) in diameter. The conveyor shall be 15’ (4.6 m) in length, with overall dimensions as shown on the drawing. The hopper shall have a 4” (100 mm) full-length outlet weir trough to minimize the overflow rate and carryover of the fine grit. The projected separator plate settling area shall be a minimum of 19.0 square feet (1.8 meters squared).

The screw shall run on anti-friction bearings at the outlet end, and a bronze bushing at the inlet end. The inlet end shaft bushing shall be capable of being greased. The inlet end shall have two 2” (50 mm) drains. Clearance between the legs and the discharge outlet shall be as shown on the drawing.

The drive to the conveyor shall be a belt-driven, shaft-mounted helical gear reducer. The motor shall be 1 HP (0.8 kW), TEFC, 3-phase, \_\_\_ cycle, \_\_\_ volt. The screw speed shall be 10 RPM. The drive shall be mounted on a plate at the discharge end and the plate shall be bolted to the flanges on the trough.

An expanded metal-flattened mesh cover shall be provided over the hopper and trough openings. The inlet opening over the hopper shall not be covered.

### **☐ MODEL 17 PISTA® GRIT SCREW CONVEYOR WITH PARALLEL PLATE SEPARATOR (FOR USE WITH A 500 GPM (31.6 LPS) CONCENTRATOR) [DEWATERING OPTION #4 – CHECK IF SELECTED]**

The PISTA® Grit Screw Conveyor shall be constructed of (epoxy coated carbon) (304 stainless) (316 stainless) steel with an inlet hopper to receive the mixture of water and grit. The hopper shall be equipped with an energy dissipation zone to prevent turbulence in the remaining portion of the hopper. The hopper shall have parallel plates located in the settling zone to improve retention of the fine grit. An overflow weir trough shall be provided to return the water to the system. The conveyor shall be freestanding with support legs to hold the conveyor at an angle of approximately 22°. The discharge shall be 12” (300 mm) diameter, plain-end pipe. The drive assembly shall be located at the discharge end.



# ENGINEERING DATA



Smith &  
Loveless, Inc.®

14040 Santa Fe Trail Drive  
Lenexa, Kansas 66215-1284

PISTA® 270™ Grit  
Removal System  
Specification  
April 2013  
Page J14

The PISTA® Grit Screw Conveyor shall have an open, 3/16" (5 mm) steel U-trough. The screw shall be 14" (355 mm) in diameter. The conveyor shall be 17' (5.2 m) in length, with overall dimensions as shown on the drawing. The hopper shall have a full-length outlet weir trough to minimize the overflow rate and carryover of the fine grit. The projected separator plate settling area shall be a minimum of 33 square feet (3square meters).

The screw shall run on anti-friction bearings at the outlet end, and a bronze bushing at the inlet end. The inlet end shaft bushing shall be capable of being greased. The inlet end shall have two 2" (50 mm) drains. Clearance between the legs and the discharge outlet shall be as shown on the drawing.

The drive to the conveyor shall be a belt-driven, shaft-mounted helical gear reducer. The motor shall be 3 HP (2.2 kW), TEFC, 3-phase, \_\_\_\_\_ cycle, \_\_\_\_\_ volt. The screw speed shall be 11 RPM. The drive shall be mounted on a plate at the discharge end and the plate shall be bolted to the flanges on the trough.

An expanded metal-flattened mesh cover shall be provided over the hopper and trough openings. The inlet opening over the hopper shall not be covered.

## PISTA® GRIT SEPARATOR SCREEN (FOR USE UP TO MODEL 7.0) [DEWATERING OPTION #5 – CHECK IF SELECTED]

The PISTA® Grit Separator Screen shall be enclosed on two sides by 11-gauge (epoxy coated carbon) (304 stainless) (316 stainless) steel plate. The top section shall contain a receiving chamber to distribute the water over the screen. The screen shall be 1/16" (1.6 mm) stainless steel wedge-wire with stainless steel reinforcing bars approximately 3/8" (10 mm) in diameter spaced at 3" (75 mm) intervals to reinforce the screen.

The screen shall mount in rubber cushioned clamp bars at each side to seal the edges against leakage. The bars shall fix the screen at an angle of 57° with the horizontal. Water from the back of the screen shall drop onto an 11-gauge (3 mm) tray and be conveyed to the rear for discharge. Inlet and discharge connections shall be as shown on the drawings.

All carbon steel parts of the PISTA® Grit Separator Screen shall be blasted with steel grit and coated by the Manufacturer with minimum 6-mil (0.06 mm) thickness VERSAPOX® epoxy resin for abrasion and corrosion protection.

## PISTA® GRIT CONCENTRATOR SUPPORT (OPTIONAL ITEM – CHECK IF REQUIRED)

A structural steel stanchion shall be provided by the Manufacturer of the PISTA® Grit Cart to support the second stage PISTA® Grit Concentrator at an elevation of 38" (965 mm) from the floor.

## AUTOMATIC SPRING-LOADED LUBRICATOR (OPTIONAL ITEM – CHECK IF REQUIRED)

The PISTA® Grit Screw Conveyor shall be provided with automatic spring-loaded lubricator which relies on the movement of the bearings to pull grease from the refillable reservoir to the bearing surface.

The reservoir and base shall be constructed of clear polycarbonate, which allows for visual inspection. The thread size is 1/8" NPT. Capacity: 6 oz. (178 cc). Size: 3" (75 mm) diameter x 6" (150 mm) tall.

Operating Temperature Range: -10°F (-23°C) to 250°F (121°C).

## CORROSION PROTECTION

All structural carbon steel surfaces shall be Factory-blasted with steel grit to remove rust, mill scale, weld slag, etc. All weld spatter and surface roughness shall be removed by grinding. Surface preparation shall comply with SSPC-SP6 specifications. Immediately following cleaning, a single 3-mil (0.08 mm) dry film thickness of red oxide primer shall be Factory-applied prior to shipment.

# ENGINEERING DATA



Smith &  
Loveless, Inc.®

14040 Santa Fe Trail Drive  
Lenexa, Kansas 66215-1284

PISTA® 270™ Grit  
Removal System  
Specification  
April 2013  
Page J15

Stainless steel, aluminum and other corrosion-resistant surfaces shall not be coated. Carbon steel surfaces, not otherwise protected, shall be coated with a suitable non-hardening rust preventative compound. Auxiliary components, such as the grit pump, gear motor, etc., shall be furnished with the original Manufacturer's coating.

Final touch-up and finish coating of the primed surfaces shall be the responsibility of the purchasing contractor, and shall be accomplished in the field. The purchasing contractor shall be responsible for ensuring that the finish coating is compatible with the above specified primer.

## MANUFACTURING QUALITY

The specified Manufacturer markets, designs, fabricates and manufactures the grit chamber equipment at its own U. S. facility. The Manufacturer shall have on staff registered engineers, both in process and design. This would be for providing current capabilities in these areas as well as future capabilities after the equipment is installed and operating, for the best long term interest of the Owner.

## INSTALLATION AND OPERATING INSTRUCTIONS

Installation and operation shall be in accordance with instructions provided by the Manufacturer.

## MANUFACTURER'S INSURANCE

ALL EQUIPMENT MANUFACTURERS, either direct or subcontractors to the general or mechanical contractors, SHALL HAVE in effect at TIME OF BID, CONTRACT AWARD, CONTRACT PERFORMANCE, and WARRANTY TERM, PRODUCT AND COMPREHENSIVE LIABILITY INSURANCE, INCLUDING SUDDEN AND ACCIDENTAL POLLUTION COVERAGE, in the amount of FIVE MILLION DOLLARS (\$5,000,000) through an insurance company with a minimum rating of A+ (SUPERIOR) XV according to the BEST'S INSURANCE REPORTS. All policies must be written on an OCCURRENCE BASIS. Policies written on a CLAIMS MADE BASIS are not acceptable. The CERTIFICATE OF INSURANCE attesting to the specified coverage issued by the responsible carrier naming the ENGINEER OF RECORD and the OWNER as ADDITIONAL INSURED, must be presented to the named additional insured prior to contract award. A FAILURE TO COMPLY with this requirement BY THE BIDDER will require DISQUALIFICATION of the BID and CONTRACT AWARD.

## STARTUP

The Manufacturer shall provide the services of a Factory-trained representative for a maximum period of \_\_\_\_ days on-site to assist with the initial startup, and to instruct the Owner's operating personnel in the operation and maintenance of the equipment.

## WARRANTY

The Manufacturer of the equipment shall warrant for one (1) year from date of startup, not to exceed eighteen (18) months from date of shipment, that all equipment he provides will be free from defects in material and workmanship.

In the event a component fails to perform as specified, or is proven defective in service during the warranty period, the Manufacturer shall repair or replace, at his discretion, such defective part. The cost of labor and all other expenses resulting from replacement or replacement of parts is not included.

The repair or replacement of those items normally consumed in service such as seals, grease, light bulbs, etc., shall be considered as part of routine maintenance and upkeep.

It is not intended that the Manufacturer assume responsibility for contingent liabilities or consequential damages of any nature resulting from defects in design, material, workmanship or delays in delivery, replacement or otherwise.



## MANUFACTURED EQUIPMENT

### **OPTION 1 (STANDARDIZATION) [DELETE THIS LINE FROM FINAL SPEC TEXT]**

The specifications and drawings detail Smith & Loveless equipment and represent the minimum standard of quality for both equipment and materials of construction. The contractor shall prepare his bid on the basis of the particular equipment and materials specified for the purpose of determining the low bid.

The Owner has standardized on the named equipment in order to optimize their operation, maintenance, and safety programs, provide for interchangeability of costly equipment items, reduce stocking levels required for necessary spare parts and provide increased flexibility in the utilization of their facility. Equipment substitutions, since incompatible with the Owner's standardization program, will not be considered.

### **OPTION 2 (BASE BID WITH BID SUBMITTAL) [DELETE THIS LINE FROM FINAL SPEC]**

The specifications and drawings detail Smith & Loveless equipment and represent the minimum standard of quality for both equipment and materials of construction. The contractor shall prepare his bid on the basis of this equipment for the purpose of determining the low bid without consideration of a possible substitute.

Substitution of other makes may be considered if the equipment proposed for substitution is superior or equal in quality and efficiency to the standards of quality named in the specifications and this is demonstrated to the satisfaction of the engineer.

Contractors wishing to offer a deduct for substitute equipment shall include the following submittal information with their proposal.

## **BID SUBMITTAL**

The submittal for consideration of unnamed manufacturers shall be submitted at least 15 days prior to the bid opening, by a bidding Contractor (not an equipment manufacturer or sales representative). It shall include all necessary information for the proper determination of the acceptability of the proposed substitution, and shall not necessarily be limited to the following:

- A. Complete description of the equipment, system, process, or function, including a list of system components and features, drawings, catalog information and cuts, Manufacturer's specifications, including materials description.
- B. Performance data and curves, and power requirements.
- C. Outside utility requirements, such as water, power, air, etc.
- D. Functional description of any internal instrumentation and control supplied including list of parameters monitored, controlled, or alarmed.
- E. Addresses and phone numbers of nearest service centers and a listing of the Manufacturers or Manufacturer's representatives services available at these locations, including addresses and phone numbers of the nearest parts warehouses capable of providing full parts replacement and/or repair services.
- F. A list of five (5) installations in the state where similar equipment by the Manufacturer is currently in similar service; include contact name, telephone number, mailing address of the municipality or installation, engineer, Owner, and installation contractor; if five installations do not exist, the list shall include all that do exist, if any.
- G. Detailed information on site, architectural, structural, mechanical, plumbing, electrical, and control, and all other changes or modifications to the design and construction work necessary to adapt the equipment or systems to the arrangement shown and/or functions described on the drawings and in the technical specifications. This shall include plan view and section sketches illustrating any additional space requirements necessary to provide the minimum adequate clear space within and around the equipment for operation and maintenance, as shown on the drawings and specified.
- H. All differences between the specifications and the proposed substitute equipment shall be clearly stated in writing under a heading of "differences".
- I. Other specific submittal requirements listed in the detailed equipment and material specifications.

# ENGINEERING DATA



Smith &  
Loveless, Inc.®

14040 Santa Fe Trail Drive  
Lenexa, Kansas 66215-1284

PISTA® 270™ Grit  
Removal System  
Specification  
April 2013  
Page J17

## EVALUATION

Approval of the substitution to bid as an alternate shall in no way relieve the contractor from submitting the specified shop drawings for approval or complying fully with all provisions of the specifications and drawings.

If substituted equipment is accepted. The contractor shall, at his own expense, make any changes in the structures, piping, electrical, etc., necessary to accommodate the equipment. If engineering is required due to substitution of alternate equipment, the contractor shall pay for all engineering charges.

To receive final consideration, copies of the Manufacturers' quotations for the equipment may be required to document the savings to the satisfaction of the engineer. It is the intent that the Owner shall receive the full benefit of the savings in cost of equipment and the contractor's bid price shall be reduced by an amount equal to the savings. In all technical and other evaluations, the decision of the engineer is final.

## TYPICAL BID FORM

**[ADD TO BID FORM AS APPLICABLE TO ABOVE SELECTED OPTION]**

### OPTION 1

For reasons of standardization, bids shall be based on the named equipment. Alternate bids will not be allowed.

### OPTION 2

Bids shall be based on the named equipment. Alternate/substitute equipment may be offered as a deduct, provided all conditions of the "manufactured equipment" section are met.

Alternate/Substitute Manufacturer \_\_\_\_\_.  
Deduct \$ \_\_\_\_\_.

# ENGINEERING DATA



Smith &  
Loveless, Inc.®

14040 Santa Fe Trail Drive  
Lenexa, Kansas 66215-1284

PISTA® 270™ Grit  
Removal System  
Specification  
April 2013  
Page J18

## PISTA® GRIT SYSTEM CERTIFICATION AFFIDAVIT

A submittal will be made to the Owner by manufacturers proposing alternate, unnamed equipment with their bid. Included in the submittal shall be full-size drawings and detailed specifications on the proposed system. Copies of the engineer's plans and specifications will not be acceptable. Included in the bid submittal shall be the following completed checklist, signed by an officer of the company.

	YES	NO
<b>PISTA® GRIT CHAMBER</b>		
Flat floor in upper chamber		
Stationary floor plate		
Heavy duty cast-iron bull gear		
Less than 1/4" (6 mm) headloss through the chamber		
Minimum of 2,500 installations		
<b>PISTA®</b> Grit Fluidizer vanes at bottom of grit hopper, within 6" (150 mm) of suction inlet (no additional hp (kW), no moving parts)		
	YES	NO
<b>PISTA® TURBO™ GRIT PUMP</b>		
Close-coupled pump design - no motor to pump shaft coupling		
Pump shaft diameter of 1-7/8" (48 mm) minimum through seal (for 4" (100 mm) pump –or– 2-1/8" (54 mm) for 6" (150 mm) pump) through seal		
Full diameter impeller shroud		
Stainless steel pump shaft		
Tapered shaft to impeller fit		
Maximum pump shaft overhang of 6" (150 mm) - lower bearing to impeller		
Bronze seal housing		
Class F motor insulation with Class B max motor temperature rise and 1.15 service factor		
Motor shaft run-out 0.003" (0.08 mm) max		
Motor shaft centered to motor base with 0.005" (0.13 mm)		
Locked lower bearing and floating upper bearing		
Ni-Hard volute		
Ni-Hard impeller		
One-piece motor adapter/backhead		
Motor HP (kW) of _____ at _____ RPM		
Priming from low-pressure area behind the impeller (Top-Mounted Only)		
Resonant frequency pump prime detection system (Top-Mounted Only)		
Transparent priming bowl for operator monitoring (Top-Mounted Only)		
Hollow priming adapter for positive seal lubrication		
Vortex-type ( <b>PISTA® TURBO™</b> ) impeller		
Minimum 2-1/2" (64 mm) equivalent opening in priming passageways		
Product liability insurance, \$5 million per specification		



# ENGINEERING DATA



Smith &  
Loveless, Inc.®

14040 Santa Fe Trail Drive  
Lenexa, Kansas 66215-1284

PISTA® 270™ Grit  
Removal System  
Specification  
April 2013  
Page J19

	YES	NO
<b>☐ PISTA® GRIT CONCENTRATOR – 250 GPM (15.8 LPS)</b>		
Solid cast Ni-Hard construction		
Minimum thickness 1-1/4" (32 mm) in high-wear areas		
No liners required		
6" (150 mm) Vortex finder		
3.5" (90 mm) Discharge Orifice		
	YES	NO
<b>☐ PISTA® GRIT CONCENTRATOR – 500 GPM (31.6 LPS)</b>		
Solid cast Ni-Hard top section and polyurethane and silicon carbide lower section		
Minimum thickness 3/4" (20 mm) in high-wear areas		
No liners required		
6" (150 mm) Vortex finder		
3.5" (90 mm) Discharge Orifice		
	YES	NO
<b>DEWATERING PISTA® GRIT SCREW CONVEYOR</b>		
Energy dissipation baffle		
Parallel plates in settling zone		
Double sided outlet weir trough (minimum weir length of 4' or 1.2 m)		
15' (4.6 m) minimum screw length		
	YES	NO
<b>STARTUP</b>		
Performed by Factory personnel		

The consulting engineer shall be the sole judge of whether the proposed equipment is acceptable. The manufacturer shall have the responsibility of submitting sufficient information in one submission. Incomplete or inaccurate submittal data shall be cause for rejection of the proposed equipment.

By an officer of the company signing this affidavit, he has stated 100% compliance with the plans and specifications or as noted in above checklist, and further states he will supply or pay for all deficiencies found in the job submittals or after the unit is installed. The consulting engineer shall be the sole judge regarding compliance with the plans and specifications and shall be sole judge on the amount of moneys required if any deficiencies are found. Generally, the amount of money shall be related to, but not limited to, a 20-year design life.

\_\_\_\_\_  
Signature of Company Officer

Corporate Seal  
(Notarized)

\_\_\_\_\_  
Title



# ENGINEERING DATA



Smith &  
Loveless, Inc.®

14040 Santa Fe Trail Drive  
Lenexa, Kansas 66215-1284

PISTA® 270™ Grit  
Chamber w/ 4" (100 mm)  
PISTA® TURBO™  
Grit Pump  
Concrete Tank /  
Remote-Mounted Models  
0.5 – 100.0  
Outline Drawing 67D135  
April 2013  
Page J21

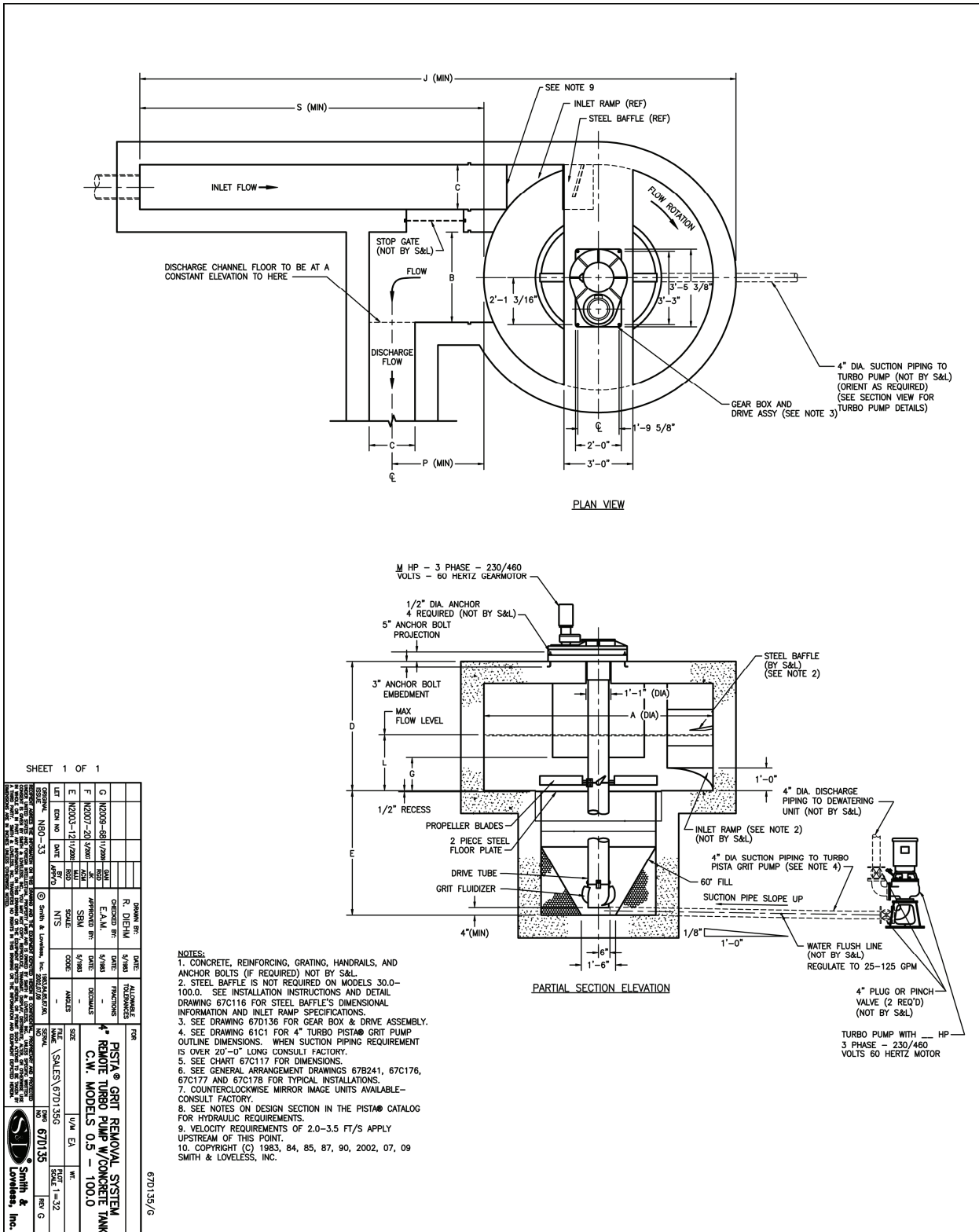

SHEET 1 OF 1

REV	DATE	BY	CHKD	DESCRIPTION
1	04/11/13	JL	SL	ISSUE FOR CONSTRUCTION
2	04/11/13	JL	SL	REVISED TO ADD 4" TURBO PUMP
3	04/11/13	JL	SL	REVISED TO ADD 4" TURBO PUMP
4	04/11/13	JL	SL	REVISED TO ADD 4" TURBO PUMP
5	04/11/13	JL	SL	REVISED TO ADD 4" TURBO PUMP
6	04/11/13	JL	SL	REVISED TO ADD 4" TURBO PUMP
7	04/11/13	JL	SL	REVISED TO ADD 4" TURBO PUMP
8	04/11/13	JL	SL	REVISED TO ADD 4" TURBO PUMP
9	04/11/13	JL	SL	REVISED TO ADD 4" TURBO PUMP
10	04/11/13	JL	SL	REVISED TO ADD 4" TURBO PUMP

**PISTA® GRIT REMOVAL SYSTEM**  
**REMOTE TURBO PUMP W/ CONCRETE TANK**  
**C/W, MODELS 0.5 - 100.0**  
 FILE # SALES 67D135G  
 DATE 04/11/13  
 SCALE 1"=32'  
 SHEET 1 OF 1  
 67D135/G

# ENGINEERING DATA



Smith &  
Loveless, Inc.®

14040 Santa Fe Trail Drive  
Lenexa, Kansas 66215-1284

PISTA® 270™ Grit  
Chamber w/ 6" (150 mm)  
PISTA® TURBO™  
Grit Pump  
Concrete Tank /  
Top-Mounted  
Outline Drawing 67B252  
April 2013  
Page J22

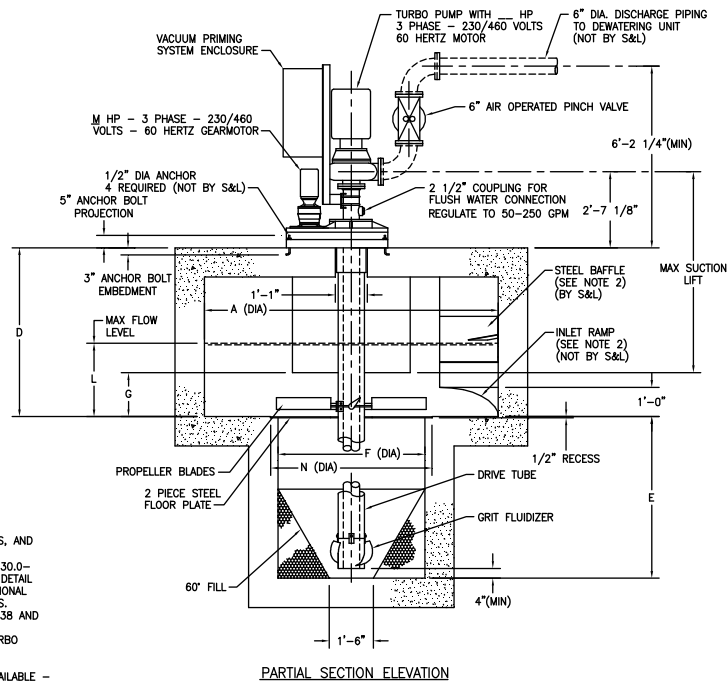
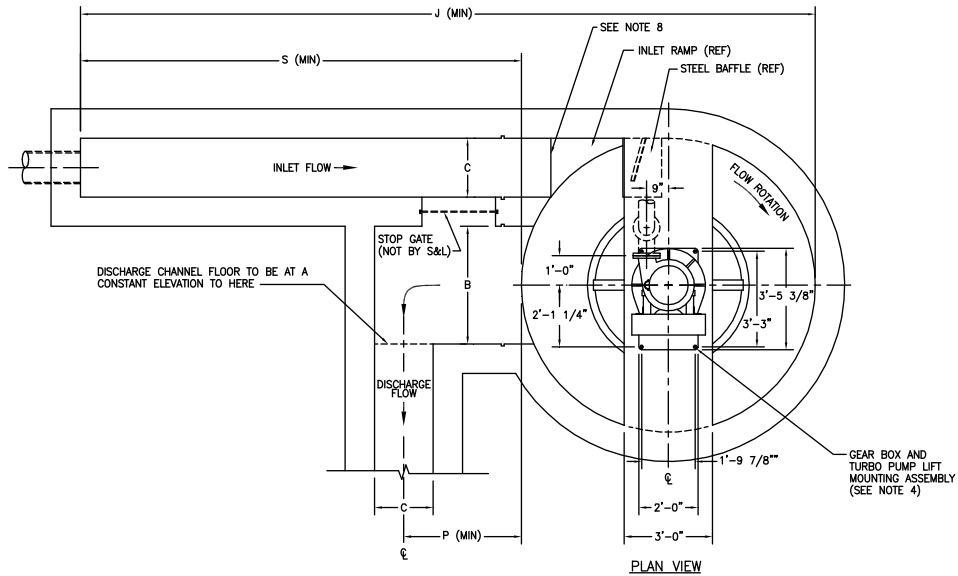

- NOTES:
1. CONCRETE, REINFORCING, GRATING, HANDRAILS, AND ANCHOR BOLTS (IF REQUIRED) NOT BY S&L
  2. STEEL BAFFLE IS NOT REQUIRED ON MODEL 30.0-100.0. SEE INSTALLATION INSTRUCTIONS AND DETAIL DRAWING 67C116 FOR STEEL BAFFLE DIMENSIONAL INFORMATION AND INLET RAMP SPECIFICATIONS.
  3. SEE GENERAL ARRANGEMENT DRAWINGS 67B238 AND 67B242 FOR TYP. INSTALLATIONS.
  4. SEE DRAWING 67D134 FOR GEAR BOX & TURBO PUMP LIFT MOUNTING ASSEMBLY.
  5. SEE CHART 67C117 FOR DIMENSIONS.
  6. COUNTERCLOCKWISE MIRROR IMAGE UNITS AVAILABLE - CONSULT FACTORY.
  7. SEE NOTES ON DESIGN SECTION IN THE PISTA® CATALOG FOR HYDRAULIC REQUIREMENTS.
  8. VELOCITY REQUIREMENTS OF 2.0-3.5 FT/S APPLY UPSTREAM OF THIS POINT.
  9. COPYRIGHT © 2003, 07 SMITH & LOVELESS, INC.

SHEET 1 OF 1

DESIGN NO.	67B252	DATE	11/2007
REV.		BY	
REV. 1		BY	
REV. 2		BY	
REV. 3		BY	
REV. 4		BY	
REV. 5		BY	
REV. 6		BY	
REV. 7		BY	
REV. 8		BY	
REV. 9		BY	
REV. 10		BY	
REV. 11		BY	
REV. 12		BY	
REV. 13		BY	
REV. 14		BY	
REV. 15		BY	
REV. 16		BY	
REV. 17		BY	
REV. 18		BY	
REV. 19		BY	
REV. 20		BY	
REV. 21		BY	
REV. 22		BY	
REV. 23		BY	
REV. 24		BY	
REV. 25		BY	
REV. 26		BY	
REV. 27		BY	
REV. 28		BY	
REV. 29		BY	
REV. 30		BY	
REV. 31		BY	
REV. 32		BY	
REV. 33		BY	
REV. 34		BY	
REV. 35		BY	
REV. 36		BY	
REV. 37		BY	
REV. 38		BY	
REV. 39		BY	
REV. 40		BY	
REV. 41		BY	
REV. 42		BY	
REV. 43		BY	
REV. 44		BY	
REV. 45		BY	
REV. 46		BY	
REV. 47		BY	
REV. 48		BY	
REV. 49		BY	
REV. 50		BY	
REV. 51		BY	
REV. 52		BY	
REV. 53		BY	
REV. 54		BY	
REV. 55		BY	
REV. 56		BY	
REV. 57		BY	
REV. 58		BY	
REV. 59		BY	
REV. 60		BY	
REV. 61		BY	
REV. 62		BY	
REV. 63		BY	
REV. 64		BY	
REV. 65		BY	
REV. 66		BY	
REV. 67		BY	
REV. 68		BY	
REV. 69		BY	
REV. 70		BY	
REV. 71		BY	
REV. 72		BY	
REV. 73		BY	
REV. 74		BY	
REV. 75		BY	
REV. 76		BY	
REV. 77		BY	
REV. 78		BY	
REV. 79		BY	
REV. 80		BY	
REV. 81		BY	
REV. 82		BY	
REV. 83		BY	
REV. 84		BY	
REV. 85		BY	
REV. 86		BY	
REV. 87		BY	
REV. 88		BY	
REV. 89		BY	
REV. 90		BY	
REV. 91		BY	
REV. 92		BY	
REV. 93		BY	
REV. 94		BY	
REV. 95		BY	
REV. 96		BY	
REV. 97		BY	
REV. 98		BY	
REV. 99		BY	
REV. 100		BY	

# ENGINEERING DATA



Smith &  
Loveless, Inc.®

14040 Santa Fe Trail Drive  
Lenexa, Kansas 66215-1284

PISTA® 270™ Grit  
Chamber w/ 6" (150 mm)  
PISTA® TURBO™  
Grit Pump  
Concrete Tank /  
Remote-Mounted Models  
20.0 – 100.0  
Outline Drawing 67B254  
April 2013  
Page J23

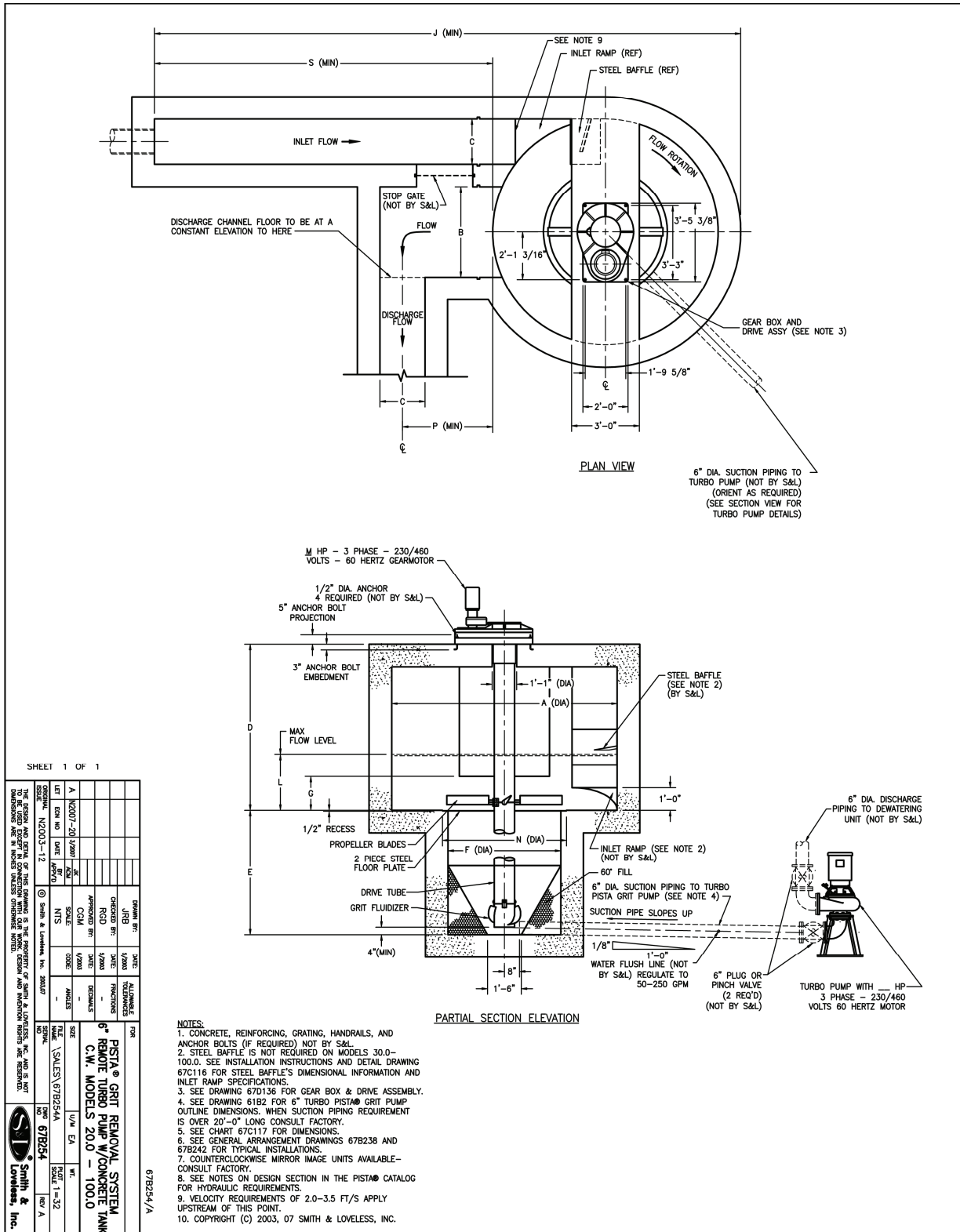

SHEET 1 OF 1

REV	DATE	DESCRIPTION	BY	CHKD
A	12/07-20/07	REVISED	SMITH	LOVELESS
B	01/08	REVISED	SMITH	LOVELESS
C	01/08	REVISED	SMITH	LOVELESS
D	01/08	REVISED	SMITH	LOVELESS
E	01/08	REVISED	SMITH	LOVELESS
F	01/08	REVISED	SMITH	LOVELESS
G	01/08	REVISED	SMITH	LOVELESS
H	01/08	REVISED	SMITH	LOVELESS
I	01/08	REVISED	SMITH	LOVELESS
J	01/08	REVISED	SMITH	LOVELESS
K	01/08	REVISED	SMITH	LOVELESS
L	01/08	REVISED	SMITH	LOVELESS
M	01/08	REVISED	SMITH	LOVELESS
N	01/08	REVISED	SMITH	LOVELESS
O	01/08	REVISED	SMITH	LOVELESS
P	01/08	REVISED	SMITH	LOVELESS
Q	01/08	REVISED	SMITH	LOVELESS
R	01/08	REVISED	SMITH	LOVELESS
S	01/08	REVISED	SMITH	LOVELESS
T	01/08	REVISED	SMITH	LOVELESS
U	01/08	REVISED	SMITH	LOVELESS
V	01/08	REVISED	SMITH	LOVELESS
W	01/08	REVISED	SMITH	LOVELESS
X	01/08	REVISED	SMITH	LOVELESS
Y	01/08	REVISED	SMITH	LOVELESS
Z	01/08	REVISED	SMITH	LOVELESS

PISTA® GRIT REMOVAL SYSTEM  
6" REMOTE TURBO PUMP W/ CONCRETE TANK  
C.M. MODELS 20.0 - 100.0

67B254/A



# ENGINEERING DATA



Smith &  
Loveless, Inc.®

14040 Santa Fe Trail Drive  
Lenexa, Kansas 66215-1284

PISTA® 270™ Grit  
Chamber Chart 67C117  
Outline Drawings 67B252,  
67B254, 67D132 and  
67D135  
April 2013  
Page J24

**PISTA® 270™ GRIT CHAMBER DIMENSIONS FOR 270° CONCRETE TANK**  
**DRAWINGS 67B252, 67B254, 67D132 AND 67D135**  
**MODELS 0.5 – 100.0 CHART NUMBER 67C117**

MODEL NUMBER	A		B		C		D		E	
	English	Metric (m)	English	Metric (m)	English	Metric (m)	English	Metric (m)	English	Metric (m)
0.5	6'-0"	1.83	2'-0"	0.61	0'-6"	0.15	3'-8"	1.12	5'-0"	1.52
1.0	6'-0"	1.83	2'-0"	0.61	1'-0"	0.31	3'-8"	1.12	5'-0"	1.52
2.5	7'-0"	2.13	2'-6"	0.76	1'-3"	0.38	3'-8"	1.12	5'-0"	1.52
4.0	8'-0"	2.44	3'-0"	0.91	1'-6"	0.46	4'-0"	1.22	5'-0"	1.52
7.0	10'-0"	3.05	4'-0"	1.22	2'-0"	0.61	4'-9"	1.45	5'-6"	1.68
12.0	12'-0"	3.66	5'-0"	1.52	2'-6"	0.76	5'-0"	1.52	6'-8"	2.03
20.0	16'-0"	4.88	7'-0"	2.13	3'-6"	1.07	5'-6"	1.68	6'-10"	2.08
30.0	18'-0"	5.49	8'-0"	2.44	4'-0"	1.22	6'-6"	1.98	7'-0"	2.13
50.0	20'-0"	6.10	9'-0"	2.74	4'-6"	1.37	8'-0"	2.44	8'-0"	2.44
70.0	24'-0"	7.32	11'-0"	3.35	5'-6"	1.68	8'-0"	2.44	8'-0"	2.44
100.0	32'-0"	9.75	15'-0"	4.57	7'-6"	2.29	10'-0"	3.05	10'-0"	3.05

MODEL NUMBER	F		G		J		L		M	
	English	Metric (m)	English	Metric (m)	English	Metric (m)	English	Metric (m)	English (hp)	Metric (kw)
0.5	3'-0"	0.91	1'-0"	0.30	21'-0"	6.40	1'-5"	0.43	¾	0.56
1.0	3'-0"	0.91	1'-0"	0.30	21'-0"	6.40	1'-5"	0.43	¾	0.56
2.5	3'-0"	0.91	1'-3"	0.38	22'-0"	6.71	1'-11"	0.58	¾	0.56
4.0	3'-0"	0.91	1'-4"	0.41	23'-0"	7.01	2'-2"	0.66	1	0.75
7.0	3'-0"	0.91	1'-6"	0.46	25'-0"	7.62	2'-6"	0.76	1	0.75
12.0	5'-0"	1.52	1'-11"	0.58	29'-6"	8.99	3'-1"	0.94	1.5	1.10
20.0	5'-0"	1.52	2'-2"	0.66	40'-6"	12.34	3'-6"	1.07	1.5	1.10
30.0	5'-0"	1.52	2'-8"	0.81	46'-0"	14.02	4'-3"	1.30	2	1.49
50.0	5'-0"	1.52	3'-9"	1.14	51'-6"	15.70	5'-10"	1.78	2	1.49
70.0	6'-0"	1.83	4'-3"	1.30	62'-6"	19.05	6'-7"	2.01	2	1.49
100.0	8'-0"	2.44	4'-6"	1.37	72'-0"	21.95	7'-0"	2.13	2	1.49

# ENGINEERING DATA



Smith &  
Loveless, Inc.®

14040 Santa Fe Trail Drive  
Lenexa, Kansas 66215-1284

PISTA® 270™ Grit  
Chamber Chart 67C117  
Outline Drawings 67B252,  
67B254, 67D132 and  
67D135  
April 2013  
Page J25

**PISTA® 270™ GRIT CHAMBER DIMENSIONS FOR 270° CONCRETE TANK  
DRAWINGS 67B252, 67B254, 67D132 AND 67D135  
MODELS 0.5 – 100.0 CHART NUMBER 67C117**

MODEL NUMBER	N		P		S	
	English	Metric (m)	English	Metric (m)	English	Metric (m)
<b>0.5</b>	3'-3"	.991	2'-0"	0.61	15'-0"	4.57
<b>1.0</b>	3'-3"	.991	2'-0"	0.61	15'-0"	4.57
<b>2.5</b>	3'-3"	.991	2'-6"	0.76	15'-0"	4.57
<b>4.0</b>	3'-3"	.991	3'-0"	0.91	15'-0"	4.57
<b>7.0</b>	3'-3"	.991	4'-0"	1.22	15'-0"	4.57
<b>12.0</b>	5'-6"	1.68	5'-0"	1.52	17'-6"	5.33
<b>20.0</b>	5'-6"	1.68	6'-0"	1.83	24'-6"	7.47
<b>30.0</b>	5'-6"	1.68	7'-0"	2.13	28'-0"	8.53
<b>50.0</b>	5'-6"	1.68	9'-0"	2.74	31'-6"	9.60
<b>70.0</b>	6'-6"	1.98	10'-0"	3.05	38'-6"	11.73
<b>100.0</b>	8'-6"	2.59	11'-3"	3.43	40'-0"	12.19

# ENGINEERING DATA



Smith & Loveless, Inc.®

14040 Santa Fe Trail Drive  
Lenexa, Kansas 66215-1284

PISTA® 270™ Grit Chamber Steel Baffle & Inlet Ramp Details  
Outline Drawing 67C116  
April 2013  
Page J26

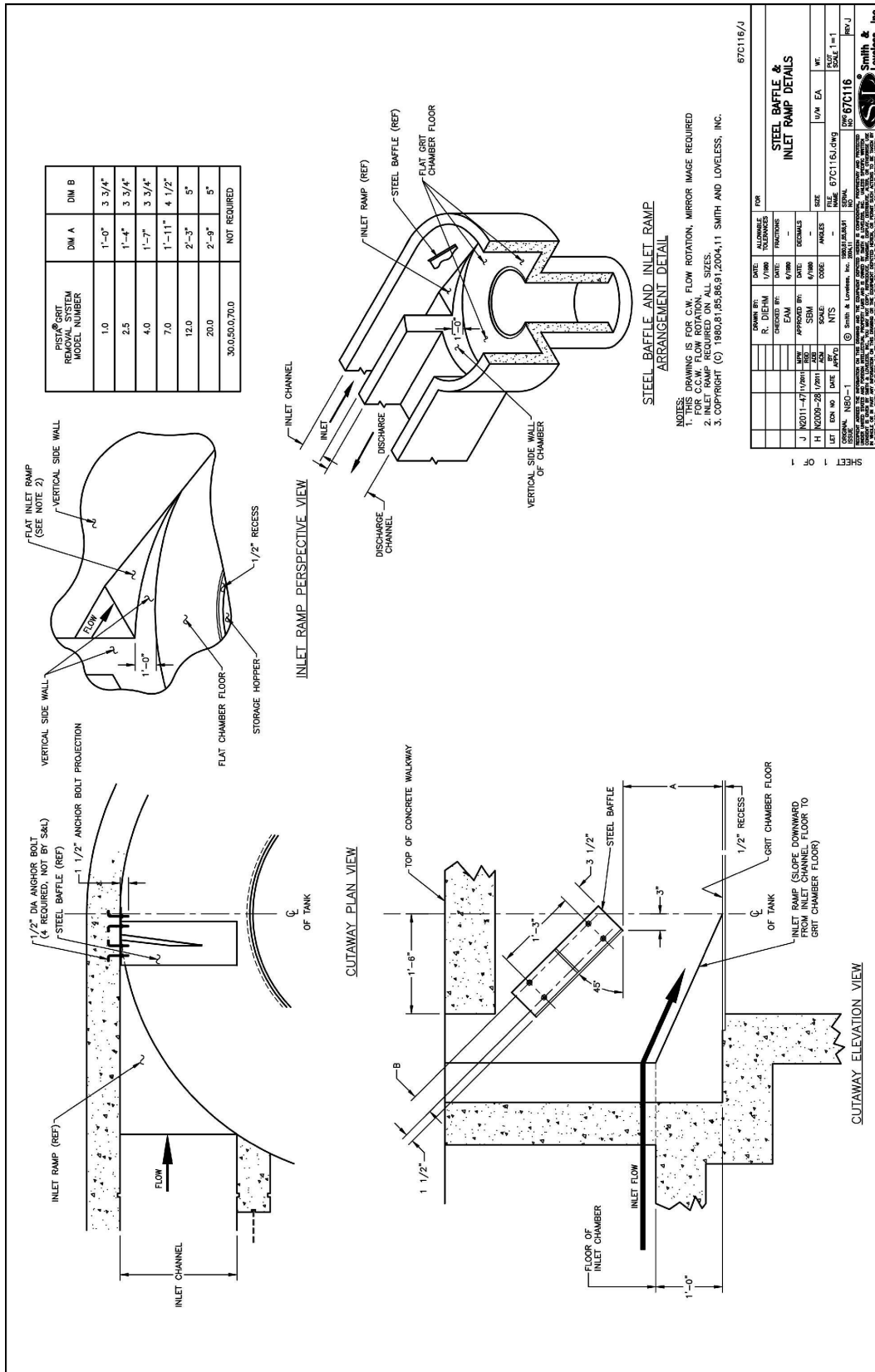

# ENGINEERING DATA



Smith &  
Loveless, Inc.®

14040 Santa Fe Trail Drive  
Lenexa, Kansas 66215-1284

PISTA® 270™ Grit  
Chamber w/ 4" (100 mm)  
PISTA® TURBO™  
Grit Pump  
Steel Tank / Top-Mounted  
Models 0.5 – 7.0  
Outline Drawing 67D133  
April 2013  
Page J27

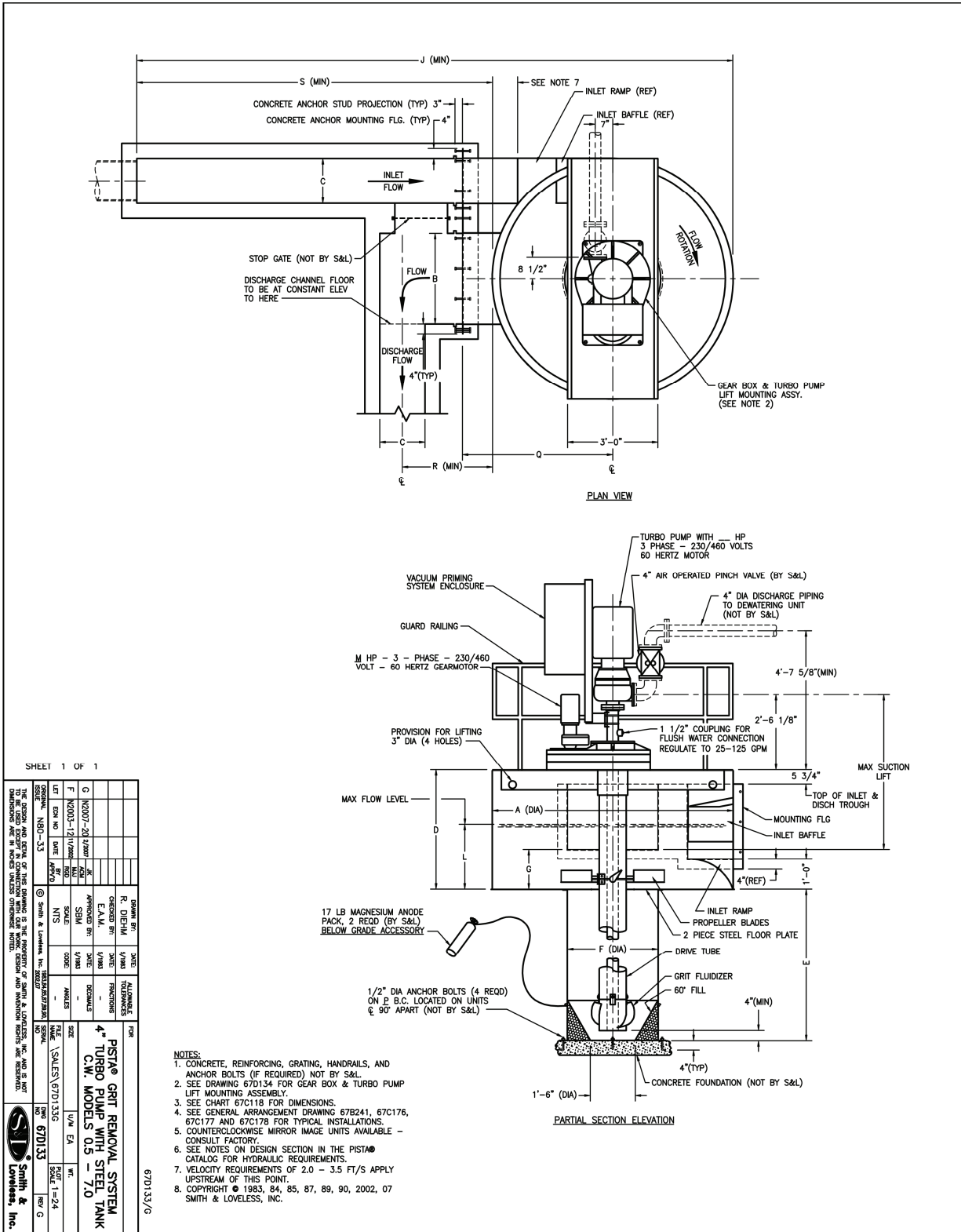

SHEET 1 OF 1

CONTRACT NO.	NSO-33	DATE	04/10/13
PROJECT NO.	67D133	SCALE	AS SHOWN
DESIGNER	R. DIEHL	CHECKED BY	E.A.M.
DATE	12/12/12	DATE	04/10/13
APPROVED BY	[Signature]	DATE	04/10/13
SCALE	AS SHOWN	DATE	04/10/13
SIZE	1/4" EA	WT.	
FILE NO.	SALES 67D133	DATE	04/10/13
REV.	0	DATE	04/10/13

**PISTA® GRIT REMOVAL SYSTEM**  
**TURBO PUMP WITH STEEL TANK**  
C.W. MODELS 0.5 - 7.0

67D133/5

